

TAPS FOR EYEBOLT: M8 DEPTH 15;  
EYEBOLTS ARE NOT ATTACHED

NOTES) Shaft dia. runout: Max. 0.05mm  
 Hub dia. eccentricity: Max. 0.07mm  
 Mounting face runout: Max. 0.10mm  
 Rated loads: Radial 4410N (450kgf)

MOTOR	INCREMENTAL PULSE CODER SERIAL PULSE CODER C			ABSOLUTE PULSE CODER HIGH RES. PULSE CODER SERIAL PULSE CODER A		
	A	B	C	A	B	C
MODEL 10	350	275	49	365	275	54
MODEL 20	425	350		440	350	
MODEL 30	500	425		515	425	

Fig. 3.3(s) Models 10S, 10S/3000, 20S, 20S/1500, 20S/3000, 30S, 30/2000, and 30S/3000 (with the brake)

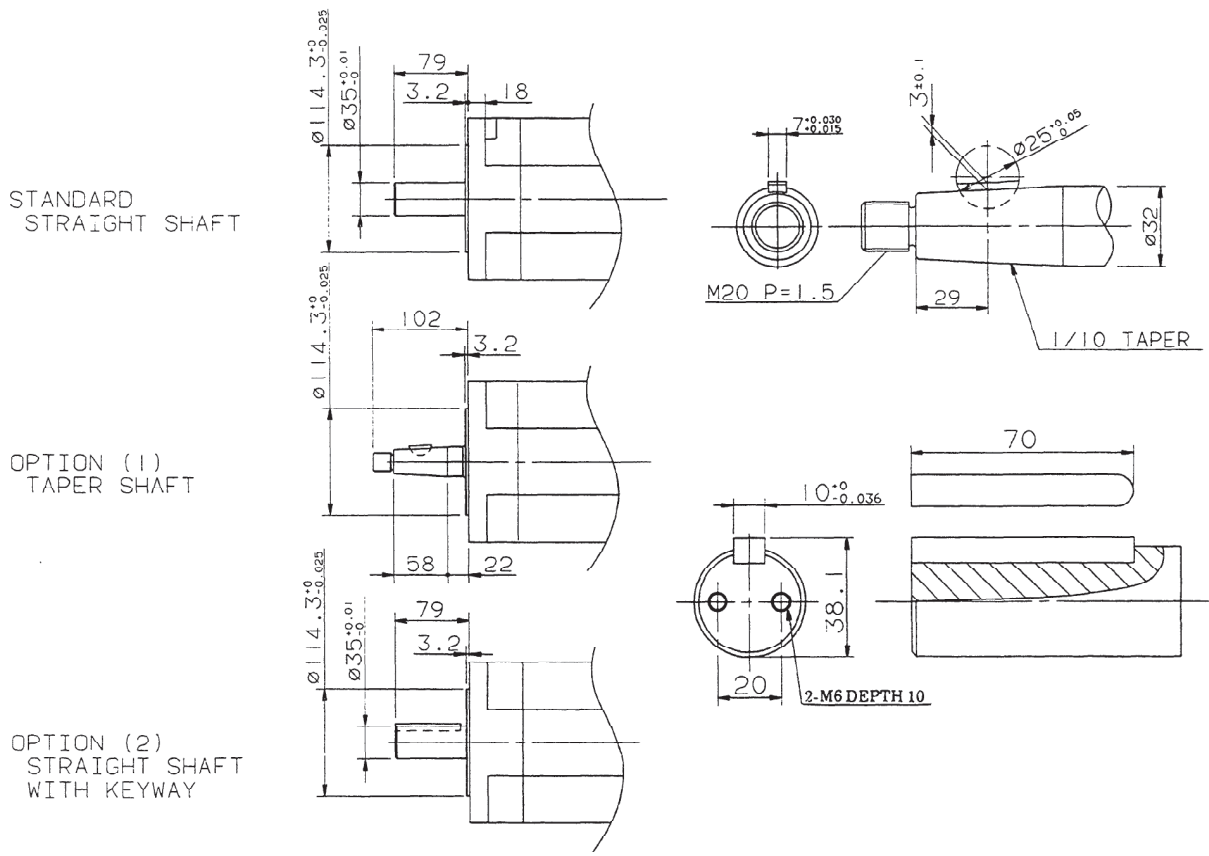

Fig. 3.3(t) Shaft option (models 10S, 10S/3000, 20S, 20S/1500, 20S/3000, 30S, 30/2000, 30S/3000)