

# ST-EP-DR-86F Series Extra Heavy Duty Machine Tool Encoders

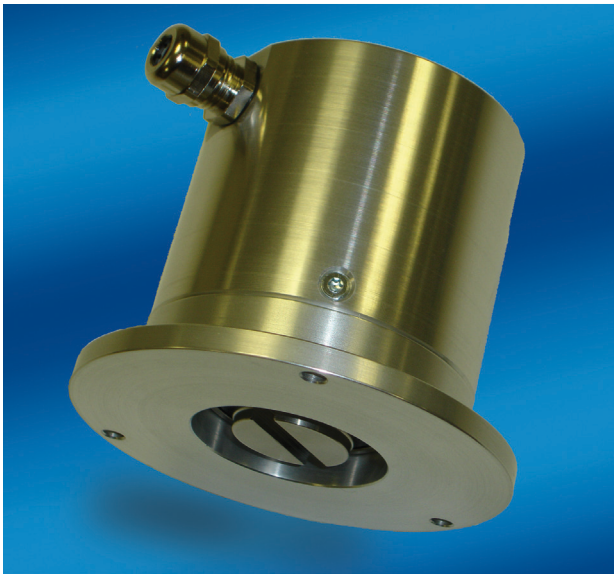

## Features

- Transverse Slotted Shaft
- Up to 3000 PPR, Opto-Asic Technology
- 90mm Round Flange with 3 4.5mm Dia fixing holes at 120° on 82mm PCD
- Double O-Ring Sealed

ST-EP-DR-86F is an extra heavy duty unit which employs a highly reliable Opto-Asic encoder module mounted within a rugged mechanical housing. The heavy duty sealed bearings, together with double O-Ring sealing makes this encoder a serious and reliable alternative to a wide range of machine tool encoders, and at an advantageous price.

## Common Applications:

Directly replaces encoders for Fanuc DC Servo Motors  
Motion Control Feedback, Conveyors, Elevator Controls, Machine Control, Food Processing, Process Control, Robotics, Material Handling, Textile Machines

## ST-EP-DR-86F Ordering Guide

Red type indicates price adder options. Not all configuration combinations may be available. Contact Customer Service for details.

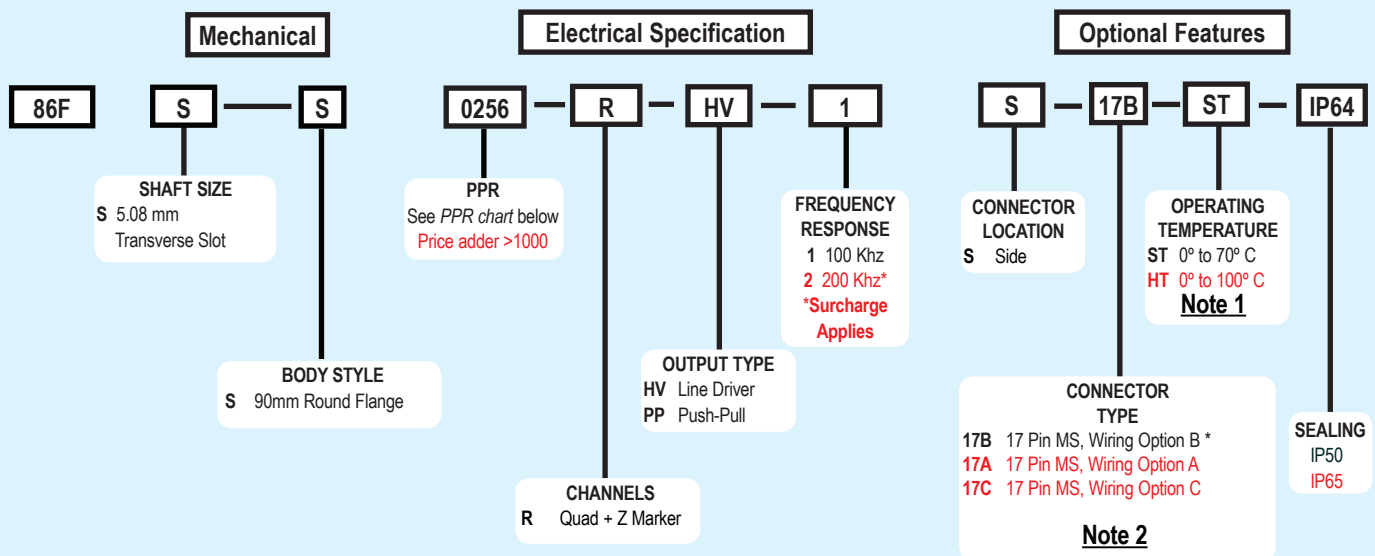

Order Number	CPR
ST-EP-DR-86F-2000-N-10	2000
ST-EP-DR-86F-2500-N-10	2500
ST-EP-DR-86F-3000-N-10	3000

### NOTES:

- 1 24 VCC max for high temperature option.
- 2 \* Option 17B = STD Wiring Code.

### ST-EP-DR-86F PPR Options

0500 0512 1000 1024 1250 2000 2048 2500 2540  
3000

This Direct Replacement Encoder provided by:



Servotech Inc  
478 Timber Ridge Road  
Middletown CT, 06457  
(866) 807 3786

Sales@servotechUSA.com

# ST-EP-DR-86F Series Extra Heavy Duty Machine Tool Encoders



## ST-EP-DR-86F Specifications

### Electrical

Input Voltage.....4.75 to 24 VCC max for temperatures up to 70° C  
 Input Current.....100 mA max with no output load  
 Input Ripple.....100 mV peak-to-peak at 0 to 100 kHz  
 Output Format.....Incremental- Two square waves in quadrature with channel A leading B for clockwise shaft rotation, as viewed from the encoder mounting face. See *Waveform Diagrams* below.  
 Output Type.....Line Driver- 20 mA max per channel (Meets RS 422 at 5 VCC supply)  
 Index.....Occurs once per revolution. See *Waveform Diagrams* below.  
 Freq Response.....Up to 200 KHz  
 Noise Immunity.....Tested to BS EN61000-4-2; IEC801-3; BS EN61000-4-4; DDENV 50141; DDENV 50204; BS EN55022 (with European compliance option); BS EN61000-6-2; BS EN50081-2  
 Symmetry.....180° (±18°) electrical at 100 kHz output  
 Quad Phasing.....1 to 2540 PPR: 90° (±22.5°) electrical at 100 kHz output  
 Min Edge Sep.....1 to 2540 PPR: 67.5° electrical at 100 kHz output  
 Rise Time.....Less than 1 microsecond  
 Accuracy.....Instrument and Quadrature Error: For 0500 to 2540 PPR, 0.017° mechanical (1.0 arc minutes) from one cycle to any other cycle.

### Mechanical

Max Shaft Speed.....3600 RPM. Higher shaft speeds may be achievable, contact Customer Service.  
 Shaft Type.....Transverse Slotted  
 Shaft Material.....303 stainless steel  
 Shaft Rotation.....Bi-directional  
 Axial Shaft Load.....35kg max  
 Starting Torque.....2.118 x 10<sup>-2</sup> typical.  
 Max Acceleration.....1 x 10<sup>5</sup> rad/sec<sup>2</sup>  
 Electrical Conn.....17-pin MS Style  
 Housing.....Anodised Aluminium  
 Bearings.....Precision ABEC ball bearings  
 Mounting.....90mm Round Flange with 3 x 4.5mm Dia Holes at 120° On an 82mm PCD.  
 Weight.....800gms typical

### Environmental

Operating Temp.....0° to 70° C for standard models  
 0° to 100° C for high temperature option  
 Storage Temp.....-25° to +85° C  
 Humidity.....95% RH non-condensing  
 Vibration.....10 g @ 58 to 500 Hz  
 Shock.....50 g @ 11 ms duration  
 Sealing.....IP50, IP64

## ST-EP-DR-86F Round Flange

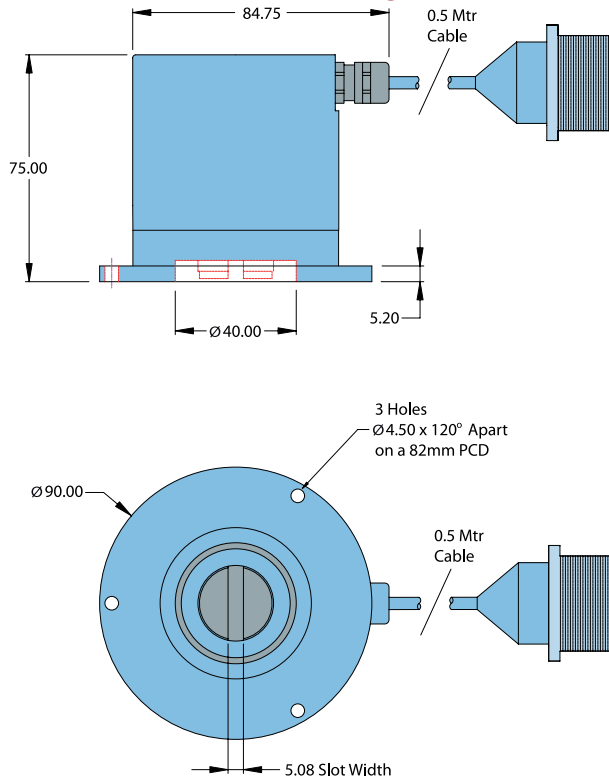

### Waveform Diagrams

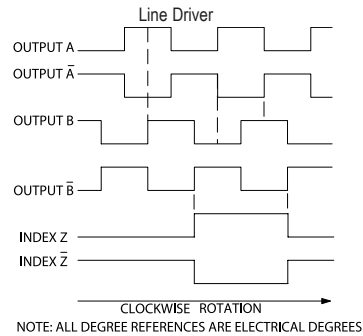

### Wiring Tables 17 Pin Connector

17pin Conn	Option A	Option B	Option C
A	A	A	A
B	Z	B	Z
C	B	+Vcc	B
D	---	/A	---
E	---	/B	---
F	---	Z	---
G	---	/Z	---
H	+Vcc	Screen	+Vcc
J	---	+Vcc	---
K	0 Volts	+Vcc	0 Volts
L	---	---	---
M	---	---	0 Volts
N	/A	0 Volts	---
P	/Z	0 Volts	---
R	/B	---	---
S	---	---	---
T	---	0 Volts	Case

Don't see the exact encoder you need replaced?

Contact us and we will be happy to cross-reference any encoder that you need replaced.

